



De Sisti Ligthing S.p.a. Head Office & Factory
Via Cancelliera # 10a Cecchina, 00040 Albano Laziale (Rome- Italy).
Tel. ..39/(0)6/934991 Fax. ..39/(0)6/9343489
INTERNET E-mail address: desisti@desisti.it
U.R.L. Address: www.desisti.it

MOTORIZED SOFTLIGHT- BOTTICELLI 5 kW



De Sisti Lighting has been committed with the professional Lighting industry for many years in developing a fully automated system, including motorized lights and suspensions that can be configured in various systems.

Thanks to a significant investment in research & development, to the experience acquired in these types of products and to the inquiries and suggestions received by the end-users, today the Company is proud to announce the availability of a State of the Art range of motorized lights, from Fresnels to Softlights, from Tungsten to Discharge type.

These motorized devices are able to accept dual input controls: Standard DMX 512 and ICARUS (Proprietary full talkback control developed by De Sisti Lighting), therefore any standard control console can be used, but, at the same time, it is possible to visualize on the monitor of the ICARUS controller the preset and live positions of the fixtures, allowing to position them in location that do not have to be necessarily available at the direct sight of the operator. The dual input is also guaranteeing a full back up facility.

The De Sisti Motorized lights can be used in combination with moving lights for effects, color changers, and any other type of motorized accessory available in the market that can be controlled via DMX.

The connections to the fixture controlled with the dual system ICARUS/DMX are:

- DMX control
- ICARUS control
- Direct Mains
- Lamp Supply (Dimmer)

FEATURES

MOTORIZED FUNCTIONS

FUNCTION	D.C. MOTOR POWER AT MAX. TORQUE	RANGE OF MOVEMENT	TIME TO EXECUTE THE FULL MOVEMENT RANGE AT MAX. SPEED	TIME TO EXECUTE THE FULL MOVEMENT RANGE AT MIN. SPEED	TOT. NUMB. OF DMX CIRCUITS	ADDRESS OF FUNCTION WITH DMX BOARD SET TO #1
PAN	55 W	370°	22 sec.	66 sec.	2	1 = Gross 2 = Fine
TILT	55 W	90°	11 sec.	33 sec.	2	3 = Gross 4 = Fine
SPEED CONTROL					1	6
					TOT. 5	

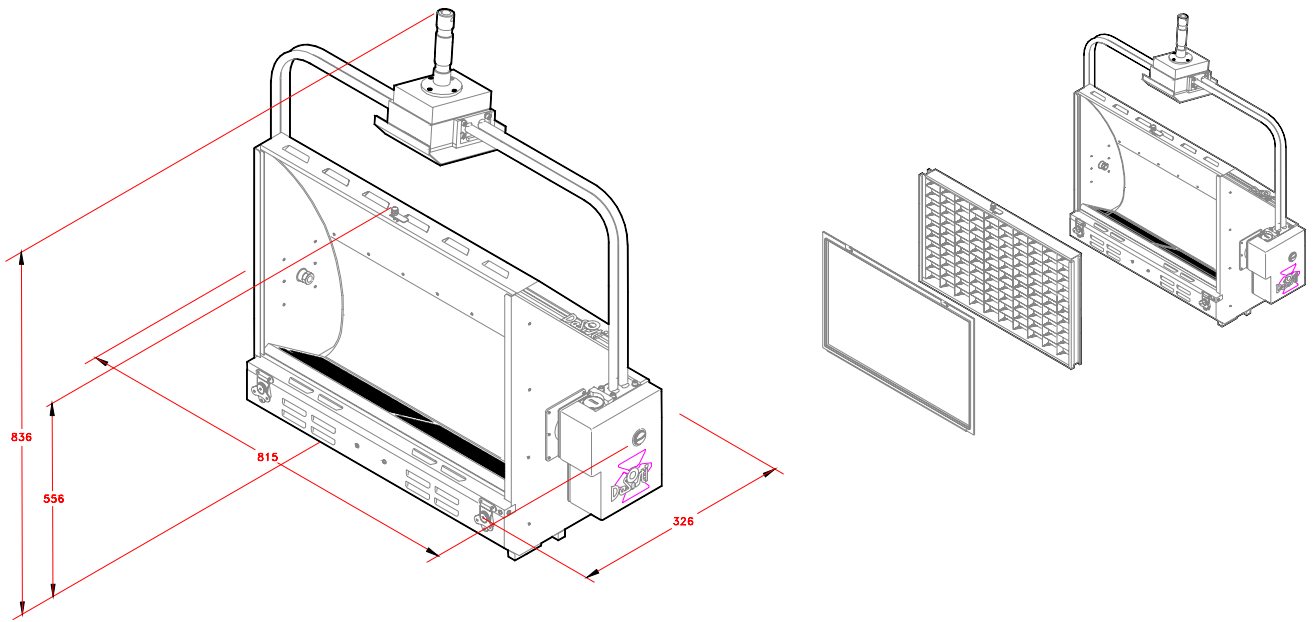

MOTION CONTROL

<p>PWM CONTROL TECHNOLOGY OF D.C. MOTORS</p>	<ul style="list-style-type: none"> • Pulse Wide Modulation technology working at 8KHz • SOFT START AND SOFT STOP: Linear regulation of the speed in start and stop operation to have smooth movements • SPEED CONTROL to vary the speed according to the application • Detection of mechanical collisions and automatics shut-off of the motors • Auto-calibration of the servo-mechanism to compensate mechanical and electrical tolerances
<p>POSITIONING SENSOR & MECHANICAL PROTECTION</p>	<ul style="list-style-type: none"> • Each motorized gear set associated to its function is built using high precision gears with negligible backlash, with a torque limiter/clutch at its output, to have a mechanical protection. The relevant positioning sensor is directly keyed to the moving object after the clutch, permitting dynamically the communication with the local microprocessor board, detecting eventual obstacles and allowing manual intervention. • Example #1: in case there is a mechanical obstruction, the motorized gear set is protected by the clutch and the software detects the status as in this condition the positioning sensor is not moving. • Example #2: in case an object (for instance the tilt of the fixture) is manually moved, the clutch will be activated and protect the output of the gear set, but the positioning sensor will move, reporting the new position to the control system. The control system has several options to handle this new status, that are at the user choice.

ELECTRONICS & MECHANICAL FEATURES

CONTROL BOARD	<ul style="list-style-type: none"> • Double input DMX/ICARUS, Opto-isolated
DMX OUTPUT	<ul style="list-style-type: none"> • DMX Opto-isolated output available at the motorized light. • Choice of either 5 pin or 4 pin XLR connector (to specify on order), to interface with DMX accessories (color scroller, mechanical shutters, etc.)
FACILITY FOR COLOR CHANGER MOUNTING	<ul style="list-style-type: none"> • The motorized Luminaire contains a power supply which is dimensioned to feed a 24V D.C. Max. 1 A load. This feature permit to use a standard Rainbow color changer, without the need to add an external box. In this case the standard DMX 4 pin connector is also carrying the power supply contacts. • It is available a special accessories holder that can be mount in front of the light and permit to slot in a standard Rainbow Changer. The accessories holder has the provisions in its front to assembly the motorized barndoor.
LOAD CENTER ADJUSTMENT	<ul style="list-style-type: none"> • The motorized light is equipped with a sliding support for the motorized stirrup. In fact by modifying the position of the rotation center to the fixture, it is possible to decide anytime weather using or not a motorized color changer in front of the unit or to add it at a later stage. The mechanism is activated by two knobs at the back of the unit and the adjustment does not require any tool.
WEIGHT OF MOTORIZED BOTTICELLI 5 kW: HEAD with pan and tilt.	<ul style="list-style-type: none"> • 35 kg.

CONTROLS

DMX STANDARD CONTROLS:	<p>The system accepts the standard DMX 512 USITT control, therefore any available product that delivers such a digital protocol can be used.</p> <p>The PAN, TILT and VERTICAL movement use 2 DMX circuits each and they are dimensioned for the 16 Bit software available with some DMX consoles. All the other items occupy 1 DMX circuit each.</p>
ICARUS CONTROLS:	<p>Proprietary protocol to control the Luminaire from a central desk. In this modality it is possible to have two controls working simultaneously (master/slave), and the available products are:</p> <ul style="list-style-type: none"> • Main Console including a floppy drive, a wireless mouse and an alphanumeric keyboard; • Compact console that connects to a standard PC configured with the ICARUS software; • Hand held remote control that has most of the functions available in the consoles. Available with cable or wireless (R.F.). <p>This protocol can support DMX version to monitor each operation of the Luminaire.</p>

PHOTOMETRICS DATA

PRODUCT NAME	BOTTICELLI 5 KW
LAMP BRAND	4 x P2/12 (1250W each)
MAINS VOLTAGE	220 V
DISTANCE PHOTOCELL in MT.	5
Light center in LUX referred to horizontal distribution	1.000
Light center in LUX referred to vertical distribution	1.000

BEAM angle	FIELD angle
↓	↓
72,0°	100,0°
80,8°	120,0°

Light center value	LUX	1.000	510	309	207
	F.C.	93	47	29	19
Light beam width with beam angle	mt.	7,27	10,17	13,08	15,98
	ft.	23' 10"	33' 4"	42' 11"	52' 5"
Light beam width with field angle	mt.	11,92	16,68	21,45	26,22
	ft.	39' 1"	54' 9"	70' 5"	86' 0"
Horizontal distribution					
	mt.	5	7	9	11
Vertical distribution					
	ft.	16' 5"	22' 12"	29' 6"	36' 1"
Light center value	LUX	1.000	510	309	207
	F.C.	93	47	29	19
Light beam height with beam angle	mt.	8,51	11,91	15,32	18,72
	ft.	27' 11"	39' 1"	50' 3"	61' 5"
Light beam height with field angle	mt.	17,32	24,25	31,18	38,11
	ft.	56' 10"	79' 7"	102' 3"	125' 0"